



Erasmus+

AGENZIA
NAZIONALE
INDIRE

PRINTSTEM

Pedagogical Resources IN Teaching Science, Technology, Engineering, Mathematics

FORECASTING THE IMPACT OF 3D PRINTING TECHNOLOGY: POSSIBILITY, FREQUENCY AND INTENSITY OF USE AS SUPPORT IN THE TEACHING OF MATHEMATICAL AND SCIENTIFIC SKILLS

Intellectual Output N. 1

Release of final validated Intellectual Output: April 2015

INDEX

Print Stem brief overview and List of Partners	p. 2
Foreword	p. 4
Chapter I - Survey and Collection of Opinions among the Experts	p. 6
I.1 The First Round Questionnaire and its results	p. 6
I.2 Results of Section A: Possibility of use	p. 8
I.2.-1.A.1 / I.2.-1.A.2 Items Relating to Criticality	p. 8
I.2.- 2.A.1 / I.2.-2.A.2 Items Relating to Priorities	p. 10
I.2.- 2.A.1 / I.2.- 2.A.2 Items Relating to Feasibility	p. 12
I.3 - Results of Section B: how to use (socio-technical variables)	p. 15
Chapter II - Towards a library of printable objects	p. 23
The Second Round Questionnaire	
II.1 - Results of Section A: Possibility of use	p. 24
II.1.-1.A. Capabilities Related to Literacy	p. 24
II.1.- 1.A.1 Mathematical Literacy	p. 24
II.1.-1.A.2 Scientific Literacy	p. 26
II.2.- 2.A Knowledge/Content Topics	p. 30
II.2.- 2.A.1 Maths: Items Relating to Priority/Feasibility for 3D Printing	p. 30
II.2. - 2.A.2 Science: Items Relating to Priority/Feasibility for 3D Printing	p. 33
II.3 Results of Section B: how to use (socio-technical variables)	p. 36
Conclusions	p. 40
Appendix I	p. 41
Appendix II	p. 45
Appendix III	p. 46

PRINT STEM BRIEF OVERVIEW

Among the causes of early drop-out from upper secondary school by students with a low level of basic competences, there is failure in the learning of mathematical and scientific literacy competences and, more generally, of formal and coded languages. According to the "Strategic Framework for European Cooperation in Education and Training (ET2020) Council Conclusions", the objective is to lower the share of 15-year old European students with insufficient abilities in mathematics and science to less than 15 % by 2020. In 2009, in Europe, the figure for students with insufficient abilities in science-related subjects, according to the PISA standard, was 17%, the share of European students who did not reach a sufficient score in mathematics was 21%.

Mathematics in particular, but other scientific subjects as well, are often perceived by students as something abstract, unrelated to their daily experiences and perceptions. This disconnect leads to lack of interest towards such disciplines and to progressive abandonment of subjects that provide an important asset in the European labour market, which is a market that offers many employment possibilities to people with those skills. For this reason, it is fundamental to develop new teaching methods that promote interest and motivation for mathematics and scientific disciplines. 3D printers are the new frontier in experimental teaching: the possibility of realizing three-dimensional models of objects conceived by the students or of mathematical or scientific concepts or objects, opens new opportunities for motivating and arising the interest of students in these disciplines.

PRINT STEM project is developing programmes and associated devices for replicable use of 3D printers, by also transferring and adapting good practices of partner countries who have already tested their effectiveness in their respective schooling/training systems. As regards the learning difficulties observed in abstract contextualization and reflective observation, the technology will help to overcome them, making it possible to focus primarily on the active experimentation and concrete experience of shapes and object that imply a deeper knowledge of formal languages.

PRINT STEM expected results:

- 1) analysis-study of the potential application of 3D print technology to experimental teaching of mathematics and science, dealing with the main problems of "low achievers", in terms of lack of attention and low interest (Intellectual Output 1);
- 2) guidelines for the setting up of an interdisciplinary team of teachers for experimental teaching with 3D printer. This way teachers will be guided towards new teaching approaches and will be invited to plan different possible applications for 3D printer technology in the teaching of their subjects (Intellectual Output 2);
- 3) conduction of 5 extracurricular project work programmes (independent learning and pupil-led experimentation) and accessible as OER, in the field of design and of product engineering technology, to discover the beauty of "making" using an interdisciplinary approach (Intellectual Output 3);
- 4) conduction of 5 experimentations aimed at the mediation of abstract concepts in mathematics teaching (teach-led experimentation), accessible as OER (Intellectual Output 4);

5) conduction of 5 experimentations aimed at the mediation of abstract concepts in the teaching of physical and natural sciences (teach-led experimentation), accessible as OER (Intellectual Output 5).

For further information, please visit <http://www.printstemproject.eu/>

LIST OF PARTNERS

PARTNERSHIP	COUNTRY
<i>Project Coordinator:</i> Istituto d'Istruzione Secondaria Superiore "A.Berenini"	Italy
Cisita Parma Srl	Italy
Istituto Istruzione Superiore "C. E. Gadda"	Italy
Forma Futuro Scarl	Italy
Kirkby Stephen Grammar School	UK
Danmar Computers Malgorzata Miklosz	Poland
Asociacion De Investigacion De La Industria Del Juguete, Conexas y Afines	Spain
Sabancı Kız Teknik ve Meslek Lisesi	Turkey
1epalchanion	Greece
Evropská rozvojová agentura, s.r.o.	Czech Republic

FOREWORD

Dear Reader,

The aim of this document is to offer a complete study analysis about the possibilities of exploitation of 3D Printers in Schools to enhance aged 15yr old students' capabilities in STEM subjects, which is when the greatest drop off occurs for schools in Europe.

As foreseen by the project, we identified a Panel of Experts both in Education (STEM teachers) and in Business (3D printing technology experts), chosen among each partner's professional network, to help us investigate the issue of STEM learning and teaching and the possible way to solve related problems thanks to the use of 3D printers in schools for didactic purposes.

In PRINT STEM Project the main problem is:

"Which may be a profitable use of 3D printing technology for the teaching of STEM disciplines?"

We need to find consent to make the project trials profitable.

To answer this question we relied upon the Delphi Method, which consists of investigating a specific problem among a selected group of people many times, until a certain degree of consent is achieved.

On this occasion we delivered a First Round and a Second Round Questionnaire to each component of the Panel of Experts.

The results from both Delphi Method sessions were elaborated and aggregated in an anonymous way.

In the First Round Questionnaire we researched the top critical capabilities in STEM subjects for aged 15yr old students, and asked the experts to rate them in a scale of priority. We also considered the socio-technical variables in using 3D printers in schools, both from teachers' and students' perspective, and asked the experts to express their view about the issue.

In the Second Round Questionnaire we started from the First Round's findings and asked each expert which physical objects (related to the top critical capability) could be actually printed both in pupil-led and teacher-led experimentations, and which didactic methodologies would suit best. Eventually we collected a useful library of printable objects, which could be actually considered for the next Outputs in PRINT STEM project.

The aim of this study analysis is to offer Partners and Schools who will lead future activities in the Project, a methodologic guideline to approach 3D Printing the best way to capture pupil's engagement and to let them make progress in STEM subjects, preventing early school drop off.

The methodologic guideline will consist of:

- STEM topics and skills which are critical for learning

- a collection of examples of printable objects

- technologies for 3D printing and related socio-technical conditions for the sustainable use at school

We hope this study will also be useful for future exploitation of 3D printing technology as replicable projects in schools.

The partner responsible for the carrying out of the Intellectual Output is Cisita Parma

CHAPTER I - Survey and Collection of Opinions among the Experts

The first round Questionnaire

Striving to answer PRINT STEM Project's fundamental question, we looked for the most appropriate way to collect significant opinions.

Our team identified two suitable targets of experts to be involved in the research: STEM teachers at one side, and 3D Printing Technology experts at the other side.

STEM teachers are supposed not only to have a full knowledge of the subject they teach, but also a deep understanding of the main problems arising in didactics and pedagogical issues.

3D Printing experts should give us instead a technical point of view about the way of using the machines, and also instruct us on the opportunities (and limitations) offered by this technology to the teaching approach.

For this reason we asked each partner involved in the project to identify two experts inside or outside their own organizations, to collaborate in the survey.

Ideally the Panel of Experts would have been composed by an equal number of teachers and of business experts: in reality teachers are much more than the business/technical staff (approximately two thirds of the panel is composed by STEM teachers).

We can of course assume that within our Partners' organizations, teachers are the most committed part in understanding the potential of 3D Printing for teaching purposes.

After setting the Panel of Experts, each Partner delivered the "Delphi Method" First Round Questionnaire to the selected experts.

In this first session 19 experts were involved in the research.

I.1 The First Round Questionnaire and its results

As stated in the submitted form, the ultimate goal of PRINT STEM project is to prevent early school drop off in students with low performance in their first or second year of secondary education.

Students aged 15 who achieve low grades in Maths and Science are at great risk of leaving education, so Institutions need to find a way to engage students awakening their interest in learning STEM subjects.

3D Printers offer students an exciting way to use STEM knowledge, enhancing their knowledge and allowing them to learn something more than by means of traditional methodologies.

To investigate the possible profitable use of 3D Printing Technology for STEM teaching purposes, we designed the First Round Questionnaire as a survey tool.

In drafting the questionnaire, in order to harmonize the contributions of each partner, it was decided to take as a reference the documents relating to the latest surveys PISA - Programme for International Student Assessment, an international survey sponsored by the Organization for Economic Cooperation and Development (OECD) every three years to assess the skills of pupils aged fifteen.

PISA aims to determine whether they have acquired some skills deemed essential to play a conscious role in society and to continue learning throughout life.

For each area of detection (reading, mathematics, science) has been developed a framework that defines the content, the cognitive processes and problematic contexts, providing the theoretical framework for the construction of the evidence.

We assumed the most recent PISA frameworks for science (draft 2015) and mathematics (2012) in order to organize a comparable set of choice of the critical learning objects (capabilities and knowledge contents/topics).

The adoption of these frameworks in support of the DELPHI method in our project is directly consistent to the objectives of two programmed experiments (teacher-led math and science trials).

It may be consistent also with pupil-led experiment, which focuses on the whole cycle of the object's creation (from design to print).

In our vision, engineering and technological skills put in practice knowledge from maths and science (as a required base): so we think the selected PISA frameworks are exhaustive for the project's purpose (to make the target of pupils aged 15 in a position to face the trials PISA effectively and prepared, achieving better results).

The First Round Questionnaire consisted of two main sections: Section A, investigating the Possibility of Use of 3D printers for STEM teaching purposes; Section B, researching the socio-technical issues attached to 3D printers' exploitation (in other words, how to use and who should operate the machine at school).

Section A (Possibility of Use) consisted on quantitative questions about maths and science learning criticalities, which experts had to rate from 1 (not critical topic for students aged 15) to 5 (top critical one). The second part of Section A displayed questions about maths and science topics and their priority/feasibility in a 3D printing trial, to be rated according to the same logic.

In the following pages you will find the aggregated data of the different parts of Section A, providing also graphics for your better understanding of the Panel's orientation.

Valid answers for Section A are 18.

I.2 Results of SECTION A: POSSIBILITY OF USE

I.2.-1.A.1 / I.2.-1.A.2 ITEMS RELATING TO CRITICALITY

The Panel results show a **similar level of criticality** for students aged 15 between mathematical literacy and scientific literacy. **Scientific literacy** on average obtained a slightly higher level of criticality (**3,81**) than **Mathematical literacy** (**3,69**).

Concerning mathematical literacy, items **E** (Devising strategies for solving problems: **4,17**), **B** (Mathematizing: **3,83**) and **D** (Reasoning and argument: **3,83**) have a higher level of criticality than average.

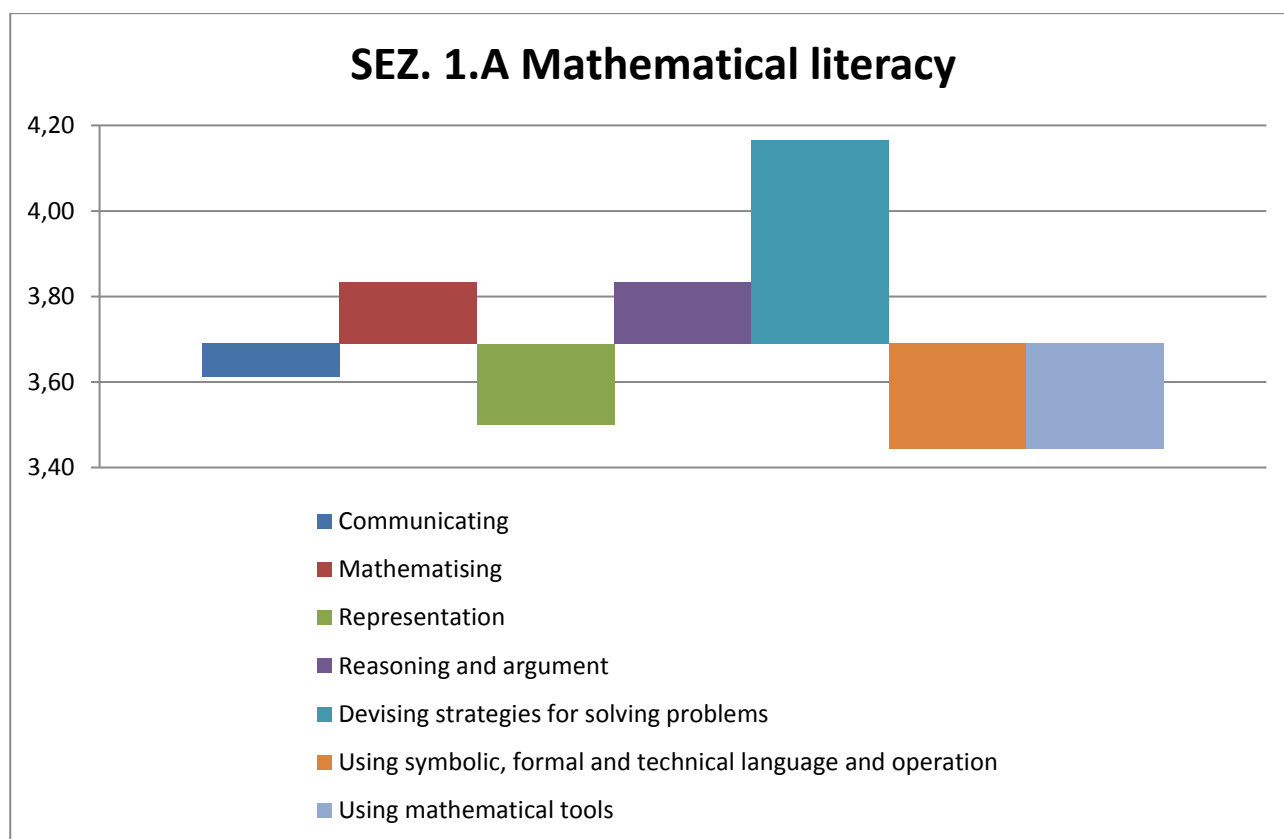

By analyzing the composition of the panel of experts we noted that 6 out of 13 teachers judge the mathematical literacy very critical for students aged 15, above average ($\geq 3,69$).

Concerning scientific literacy, items C (Interpret data and evidence in a scientific way: **3,89**) and A (Explain phenomena scientifically: **3,83**) have a higher level of criticality than average.

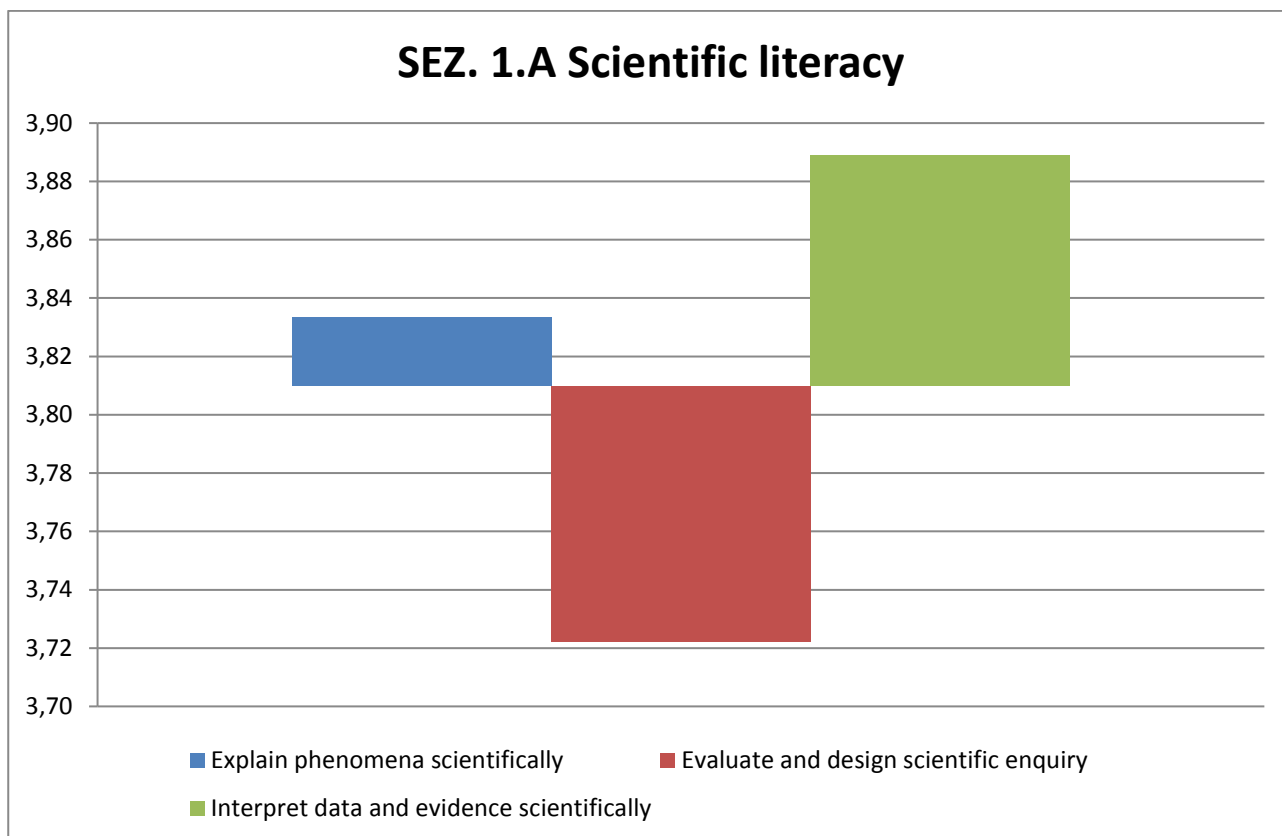

By analyzing the composition of the panel of experts we found out that 9 out of 13 teachers judge the scientific literacy very critical for students aged 15, above average ($\geq 3,81$).

I.2.- 2.A.1 / I.2.-2.A.2 ITEMS RELATING TO PRIORITIES

In terms of average priority, mathematical literacy (2,81) and scientific literacy (2,73) are fundamentally equivalent.

Concerning mathematical literacy, items with a higher level of priority than average ($\geq 2,81$) are:

- E (Relations within and between geometric objects in two and three dimensions: 4,17)
- F (Measurements: 4,11)
- D (Coordinate Systems: 3,12)
- I (Percentages, ratios and proportions: 3,11)
- A (Functions: 2,89)
- G (Numbers and Units: 2,83)
- L (Data collection, representation and interpretation: 2,83)

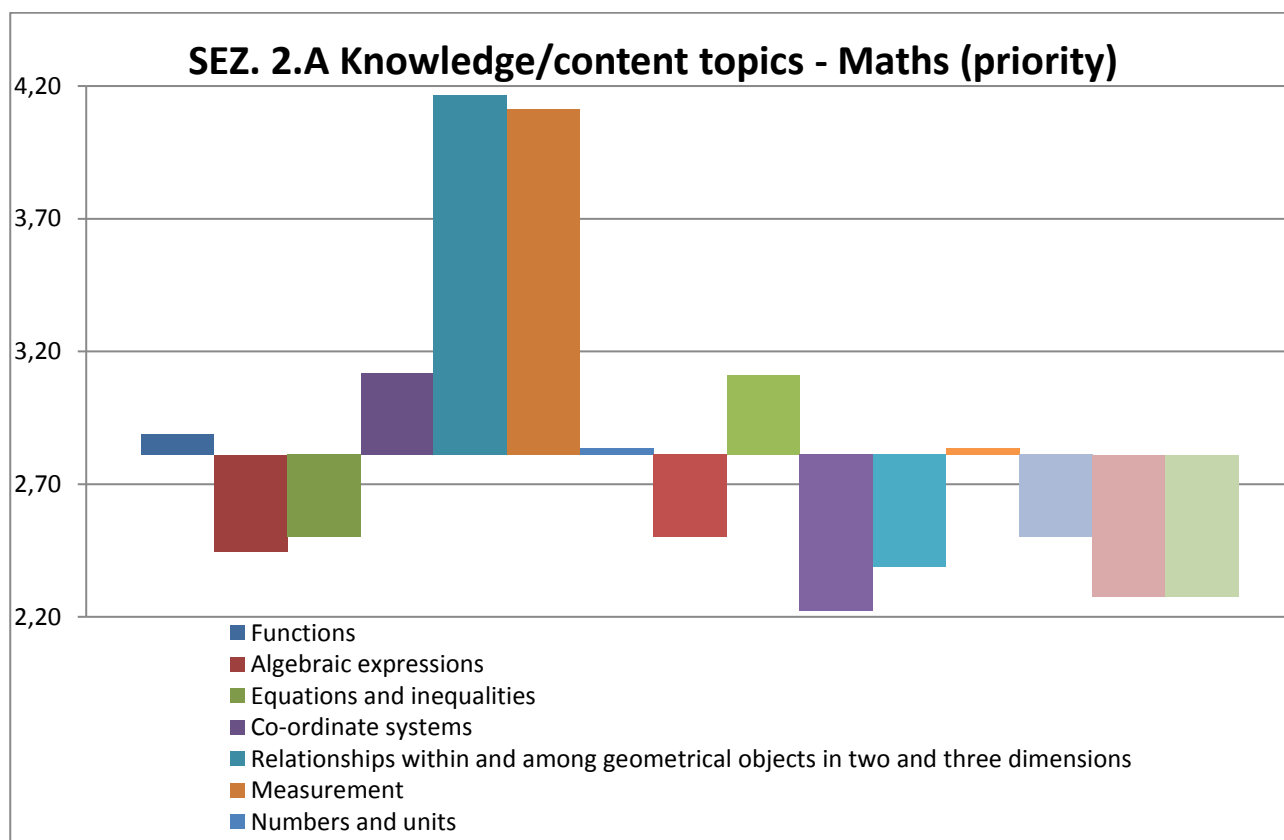

Concerning scientific literacy, items with a higher level of priority than average ($\geq 2,73$) are:

- A (Structure of matter: **3,89**)
- D (Motions and forces, action at a distance: **3,50**)
- G (Cells: **3,33**)
- Q (The Earth in space: **3,33**)
- I (The Human Body: **3,28**)
- B (Properties of Matter: **2,88**)

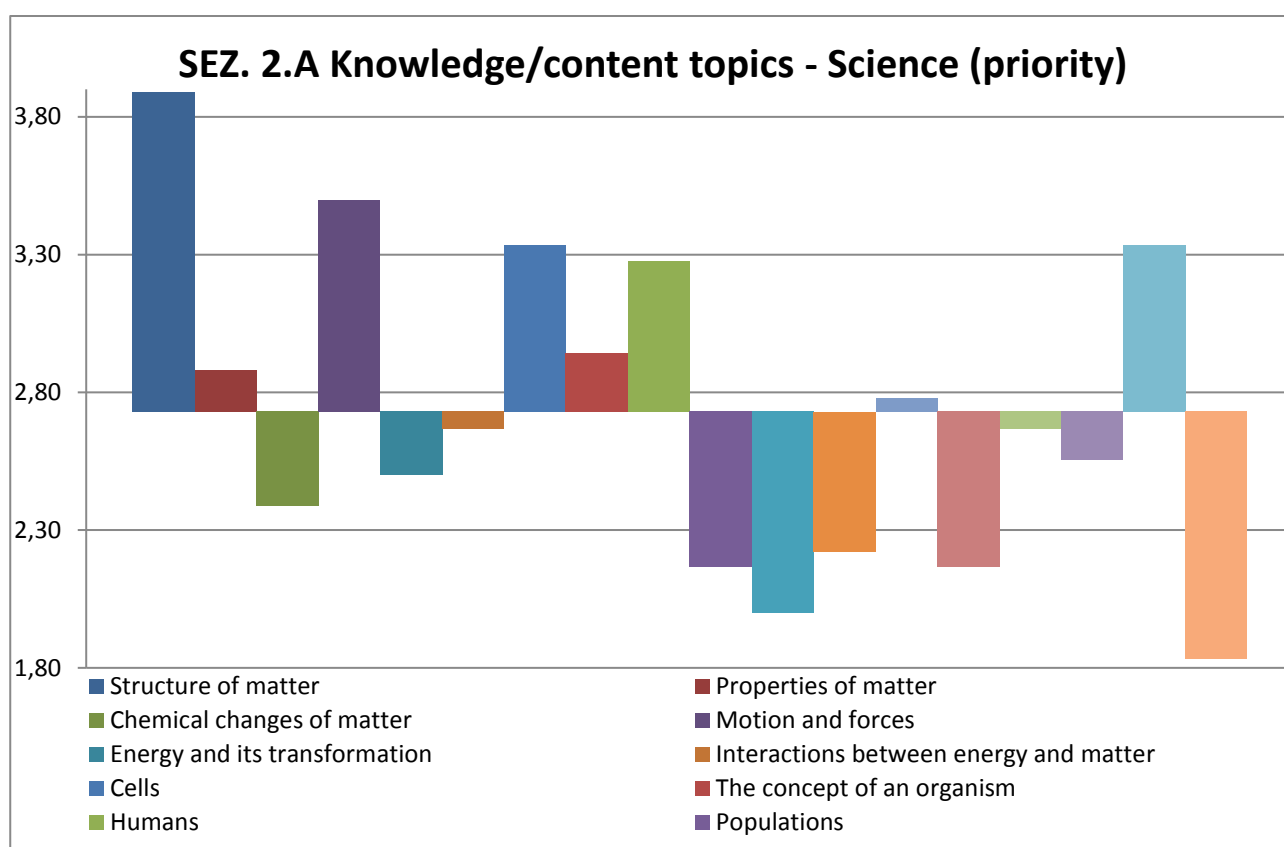

I.2.- 2.A.1 / I.2.- 2.A.2 ITEMS RELATING TO FEASIBILITY

As it has been noted that mathematical literacy is slightly less critical than scientific literacy, mathematics is considered on average more feasible for 3D printing (3,26) compared to the sciences (2,73).

Concerning mathematical literacy, items with a higher level of feasibility than average ($\geq 3,26$) are:

- F (Measurements: 4,50)
- E (Relations within and between geometric objects in two and three dimensions: 4,44)
- D (Coordinate Systems: 3,82)
- I (Percentages, ratios and proportions: 3,72)
- G (Numbers and Units: 3,50)
- A (Functions: 3,39)

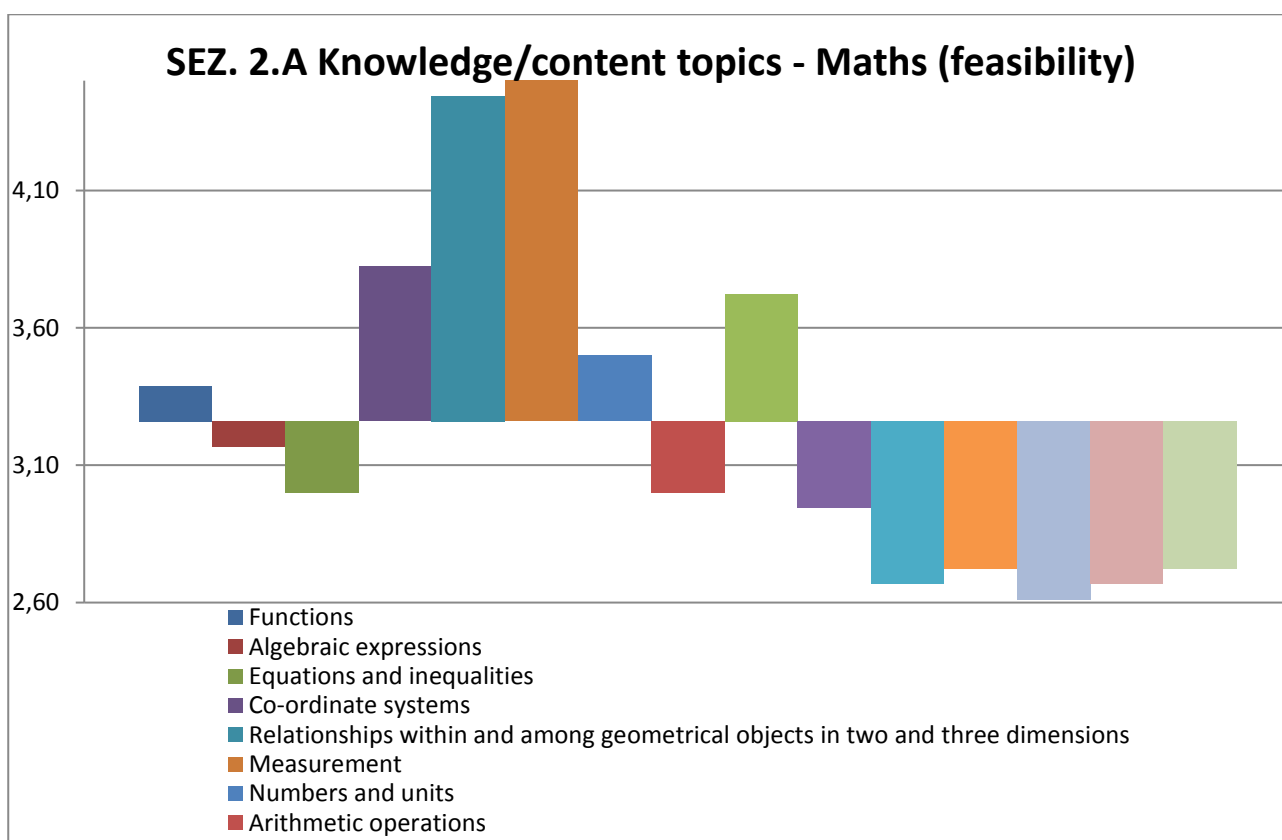

Concerning scientific literacy, items with a higher level of feasibility than average ($\geq 2,73$) are:

- A (Structure of matter: **3,78**)
- G (Cells: **3,67**)
- D (Motions and forces, action distance: **3,56**)
- I (Human Body: **3,28**)
- Q (The Earth in space: **3,06**)
- B (Properties of Matter: **3,00**)

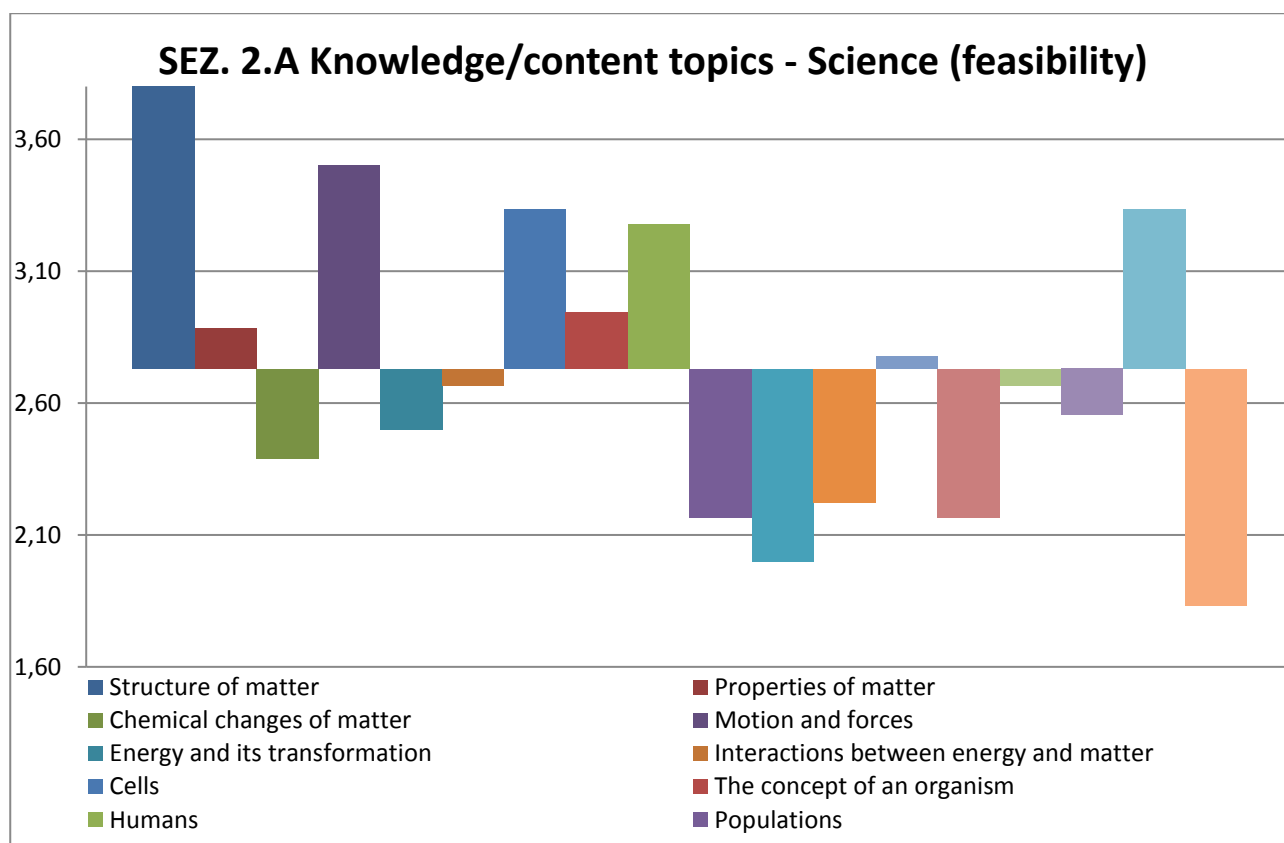

It's important to note the following result: regarding both disciplines (mathematics and science), the items judged to have higher priorities are also judged more printable.

We also highlight below some more Items / Topics which were not included in the questionnaire but were suggested directly by the experts in the notes:

Mathematical Literacy

CAPABILITIES:

- Reasoning and Proof (Evaluating concepts, relationships and cognitive reasoning process, demonstration and metacognitive strategies employed, Inferred properties and methods, Deducting, generalized and applied properties of numbers and shapes, Discovering mathematical relationships between different sets of numbers and figures; Demonstrating the validity or invalidity of an argument). **VALUE 5**

TOPIC:

- Calculation of integers Z and rational Q , in particular the conversion from fractions to finite or infinite decimals, and conversely, and approximations and evaluation of the order of magnitude. **VALUE 4**
- Making measurements, in particular angular ones, successfully converting between different units of measurement, forming hypothesis about the possible outcome of a measure, identify any data or results of computational processing which are inconsistent with the context. **VALUE 4**

Scientific Literacy

CAPABILITIES:

- Understanding spatio-temporal (Identifies Causes and relationships, problematic situations. Historical and geographical processes. Metacognitive strategies used in spatiotemporal understanding). **VALUE 4**

TOPIC:

- TRANSFORMING THE CIRCULAR IN LINEAR MOVEMENT
Priority Value 3; Feasibility Value 5
- ASSEMBLY SEVERAL PARTS TO DEVELOP EXPERIMENTS
Priority Value 3; Feasibility Value 4

I.3 - Results of *SECTION B: HOW TO USE (SOCIO-TECHNICAL VARIABLES)*

In Section B of the First Round Questionnaire we asked the Panel its opinion about *who* should be involved in the entire process of 3D Printing experiments in schools, and *how* machines should be operated.

Talking about *who* should use the 3D printer, opens to us a wide landscape of possible actors in this project. Let alone students are the final users and the ultimate beneficiaries, there are many figures playing an important role: 3D printing experts, teachers and school staff, ICT specialists and technicians.

A big question arises in STEM teachers' minds: how can school staff learn to use 3D printers and deliver effective trial sessions to the students?

For this reason we asked the Panel to express its view about:

- what kind of experts should be involved in PRINT STEM project and which fields of knowledge they should have
- whether or not STEM teachers should receive a training in 3D printing technology and at which level
- which kind of teaching approach would suit best to engage students in the project
- how to involve 3D printing and business specialists in this project
- how to manage the accessibility to the 3D printer machine for students
- the technical issues attached to the choice of a 3D printer, and which specific logic they would go for (make/buy logic)

We refer to all these issues as socio-technical variables.

Each expert answered open questions with the chance to write their considerations freely (no ratings requested). In the following pages you will find the aggregated results for each questions, in the form of keywords and trends emerging from the questionnaires.

Concerning very specific information about hardware and software choice, you will find a relevant section at the end of this document (see appendixes below).

Valid answers for SECTION B are 18.

Question 1 - What kind of experts do you think is important to involve?*Keywords*

- Experts in 3D Printing Technology
- ICT Experts
- Engineers & Architects
- CAD designers
- Teachers of STEM subjects
- Experts in pedagogy and educational issues

Question 2 - What knowledge and skills must the experts have?*Keywords*

- Computer Knowledge
- CAD & Industrial Design Skills
- Knowledge of Materials
- Knowledge of Electronics
- English language skills
- Awareness of 3D Printers opportunities and limitations for teaching purposes
- Awareness of the learning difficulties of the students
- Good pedagogical approach

Question 3 - DEDICATED TRAINING: Do you think useful/necessary making teachers more informed about use of the printers with specific technical training?

We have identified a few trends about this issue among the panel.

a) NOT USEFUL

"Teacher training is not useful or necessary. Schools don't have enough time to program new activities"

b) BASIC TRAINING ONLY

"Teacher training would be useful to inform them about a basic use of 3D printers, to understand how 3D printers work and carry out the project. 3D printers are not used in schools right now, so such training is necessary to raise awareness."

"Initially teachers don't need to have any knowledge as the machine operation is very simple, and with a simple training of a few hours, they could make the machine start and work, but eventually it would be advisable to train teachers a little on the subject to get more from the printers, and to improve teaching."

c) SPECIFIC AND INTENSIVE TRAINING IS NEEDED

"Not necessarily programming, but 3D modeling and IT knowledge are must for teachers. Without extensive training, most teachers will not be able to use 3D technology at all."

"It is vitally important that all teachers involved in the project have specific training, particularly when using the design software. Without specific and effective training it will be impossible to deliver effective experimentation of any value."

Question 4 - TEACHING APPROACH: Do you think useful/necessary making teachers more informed about new approaches to teaching?

We have identified a few trends about this issue among the panel.

a) NOT A PRIORITY

"No, this would not be effective in terms of students' learning"

"Teachers should be informed but just as an additional information. I don't see this topic as a top priority because teachers must not be forced to radically change their vision of the subject they teach or the way they interact with their pupils. [...]"

b) TRADITION AND INNOVATION GET ON WELL TOGETHER

"Actual society has evolved very quickly in a few years, and students need to keep abreast of new technology to prepare for the future. [...] I think the traditional teaching should not disappear at the beginning of learning, but this field shows students have new needs and new concerns."

c) A VARIETY OF NEW TEACHING STRATEGIES IS NEEDED

"Teachers involved in the study must be well informed with a variety of teaching strategies and be able to apply a flexible approach to learning. Without a flexible approach to teaching and learning a full spectrum of experimentation cannot be applied to the project."

" New, pupil-centred teaching methods help students to get more involved. Such initiatives facilitate pupils' creativity, teamwork and drawing conclusions. It would be great to have it commonly practiced in schools."

"[...] From my own experience I know for sure that in an environment where a teacher is more like a mentor than a leader leads to far better results than having a blindfolded pupil group following instructions without a question. "

Question 5 - How Can You Program The Involvement Of Business Experts/Technical Partners? (eg. Cad Experts, Computer Programmers, Technologists of printing process, Others – specify)

We have identified a few trends about this issue among the panel.

a) NOT FEASIBLE

"I don't know / Honestly I don't see it at all in current reality"

"It's very hard. School is a separate world from business and there are not funds at all"

b) FEASIBLE THROUGH PARTNERSHIPS WITH EXTERNAL INSTITUTIONS

"This could be done contacting Fab Lab Makers, 3D prototyping laboratories and technical Universities"

"The involvement of technical and business experts can be achieved by intensive courses and meetings that highlight the practical use of 3d printer in the working world [...]. "

c) FEASIBLE THROUGH PROMOTION ACTIVITIES/SPONSORSHIP

"It could be introduced as demo-lessons or could be used in extracurricular activities during hobby/interest clubs. Demonstrating large-scale 3D printing, non-standard solutions may increase interest of the pupils in this technology and facilitate their drive to increase their competences."

"For example involving publishing groups who finance the development of new proposals drawn from the findings of the project, which will ultimately be who, in addition to what is commonly offered, give added value to its agenda. "

Question 6 - Do you think it's important (and how much) a COOPERATIVE WORKING between experts from different categories? How can it be realized?

We have identified a few trends about this issue among the panel.

a) IMPORTANT BUT DIFFICULT

"It's Important but I don't know how to achieve it"

"Cooperative working can be effective in some situations however it can be difficult to program into work schemes or projects due to time and physical location issues"

b) VERY IMPORTANT AND FEASIBLE

"Yes, it is very important. Specialist should exchange their knowledge and experience. Peer consulting and common workshops and trainings might be very helpful. It may occur that specialists from different sectors pay attention to different things, and of course they provide support in their own field of expertise."

"[...] This can be easily realized by organizing for example groups of pupils with different goals but a common greater objective that can be achieved only through cooperation. The key is the understanding that there is no competition present but only the fun of imagine-expand and create. It is a common situation that when numerous experts of different fields are to be found in the same field of practice, some kind of competition and arrogance arises. "

Question 7 - Do you think it's important (and how much) the presence of people permanently dedicated to technology for on-going support?

We have identified a few trends about this issue among the panel.

a) YES, PERMANENTLY

"Yes, for safety reasons inside the school"

" Yes, because technical/maintenance issues are apart from didactic"

"Yes, it's important because low cost 3d printers often have problems"

"It's very important because if there is not people permanently dedicated to technology, then if a printer failure occurs, even the most insignificant, the printer will remain off and use thereby loses its usefulness"

B) JUST REMOTE /INITIAL ASSISTANCE IS ENOUGH

"The need for support will be necessary initially. However as projects develop and teachers gain more confidence, less support will be needed. [...] As teachers become more familiar with the project's software and hardware they can anticipate problems and will have already solved many of them in the pilot study before actually teaching them."

"[...] One experienced technician with one assistant is enough to sufficiently cover the needs of 5-6 schools. Although, the real problem someone should consider is the acquisition of a stock of spare parts as replacements of malfunctioned ones."

Question 8 - Do you think it's important (and how much) the logistics of using the printer (like the accessibility of the machine as a motivational factor)?

We have identified a few trends about this issue among the panel.

a) NOT IMPORTANT

"No, it wouldn't influence 3D printer's exploitation at all. There are too many logistics problems in schools"

"I don't think that, after an initial moment of interest and curiosity, printer logistics should be given an high priority."

b) VERY IMPORTANT

"Very important. In my opinion access should be supervised by teachers/technical support, but free for students".

"Pupils who will be using the printer will definitely be inspired by its possibilities. The opportunity to realize an idea into a 3D product will be a motivating factor for pupils. It will enhance their interest towards STEM subjects and improve their desire to learn. Pupils with poor abilities will have the chance to see tangible results and this will awaken their interest towards their lessons."

"Accessibility of the printer is probably the most important aspect of this project. One of the advantages of using 3D Printers is there's ease of use and lack of any real hazards, making it the ideal machine for pupils of virtually any age to use. Any learning or educational experience is always improved and given greater understanding when pupils actually touch, use and take ownership of that experience."

Question 9 - Do you prefer to create from scratch the contents of experimentation ("MAKE" LOGIC)?

We have identified a few trends about this issue among the panel.

a) "MAKE" LOGIC SHOULD NOT BE USED

"I don't think 'make' logic should be used. It requires greater knowledge, more time and more support of third parties"

"At first, "make" logic should not be used. As it happens in many fields of knowledge, in particular in technical ones, the best approach is known as "reverse engineering". In this case, we should use already made models and, in the meantime, study them to learn how they were made. This should develop a generation of users capable of moving, in later and expert stages, towards the "make "logic."

b) LET'S GO FOR A MIXED SOLUTION

"I would propose mixed solution. Get models and design from external sources and modify them according you the education needs. Developing models for 3D printing takes a lot of time. There is no point in developing something that already exists – with the exception if the process brings educational value. There is also a matter of time, complex models can take several hours of work to design them, I don't see that working in the typical classroom setup."

c) "MAKE" LOGIC SHOULD BE USED

"It is preferable to create from scratch. It may seem quite hard to create from scratch as a beginner in 3D designs however this will accelerate the learning process of both teachers and pupils. Having the chance to create your idea into a 3D product will contribute to their active learning. Initially after a trial-error period they will learn how to create their own ideas into solid designs."

Question 10 - Do you prefer to purchase existing contents, eg. free program or freely downloadable designs from websites ("BUY" LOGIC)?

We have identified a few trends about this issue among the panel.

a) "BUY" LOGIC IS MORE REALISTIC

"Yes, because it's unrealistic that teachers and students create from scratch models and designs. Things get easier if they can follow a model."

"This choice is more realistic: using existing contents makes the start of the experimentation easier and with less trouble. During the initial phase of the project it is necessary not to lose the students interest and too many problems lead to discouragement. After this first phase you could switch to 'make logic'."

"The 'buy' logic is the first approach to this subject. A freeware model, for example, is extremely satisfying for a beginner because it gives him/her a quick result without leaving him/her tangled too much in the process of making. Making from scratch would force him to a slow path, maybe more

rewarding in the long range but subject to early-drop, frustration and other side effect of a steep curve of learning. As I said, the 'buy' logic is needed in my opinion not as a substitute of the 'make' logic but as a necessary prologue that naturally leads to it."

b) 'BUY' LOGIC IS NOT THE BEST OPTION EVEN FOR BEGINNERS

"In some cases it will be useful, but first option is better. You make less effort, but maybe you don't understand real objective of the 3D model downloaded. Also, you don't involve pupils in the experiment."

"I don't think to buy it is a good option. If you find some free libraries from the internet then this is a good option, but if you pay some developers to obtain your files, you need a lot of money, which schools often lack. It could be a solution that many schools meet, each pays one, two or three designs, and then share all: this is not so expensive."

CHAPTER II

Towards a library of printable objects

The second round Questionnaire

As stated before, the Delphi Method consists of investigating a specific topic by asking the same group of people (Panel) many times about the issues of the research, until a common consent is eventually found.

Since a full Report of feedback about the evidences from the First Round Questionnaire was delivered to the Panel, in Second Round Questionnaire we started from the results of the First Round, and tried to go further.

We wanted to understand whether the same experts acknowledged the outcomes or not, by displaying them the aggregated results and asking them to confirm or contradict the statements, giving reasons for their choice.

We kept the same structure of the first questionnaire: Section A about the *possibility of use* of 3D printers in school, and Section B about *how to use* and manage the machine at school.

In Section A of the Second Round Questionnaire we showed the results of the quantitative questions of the First Round one, and asked to the Panel to state first whether they agreed or not with the capability/topics selected as most important.

Second, we asked them to make some proposals about a library of physical objects which could be actually printed both in pupil-led and teacher-led trials, foreshadowing (and possibly designing as well) an ideal didactic setting or methodology to run the experiments effectively.

In the following pages you will find a full picture of the Panels response as a whole, taking into account also agreement or disagreement statements.

The Second Round Questionnaire was delivered to 18 experts. Valid answers are 17.

II.1 - Results of SECTION A: POSSIBILITY OF USE

II.1.-1.A. CAPABILITIES RELATED TO LITERACY

II.1.-1.A.1 MATHEMATICAL LITERACY

Concerning mathematical literacy, according to the results of First Round Questionnaire top critical item is:

DEVISING STRATEGIES FOR SOLVING PROBLEMS with 4.17 average

In the Second Round Questionnaire, although two experts declared themselves skeptical about anything useful in the curriculum of mathematics or geometry for aged 15yr old pupils which could be used for 3D printing, some experts also pointed out further capabilities that should be involved to design an effective 3D printing **pupil-led** experience:

- **Reasoning and argument** (see Pisa list), "because with their own initiative and reasoning the students themselves have gathered evidence, they will be able to develop strong problem solving skills."
- **Representation** (see Pisa list)
- **Computer Science** (out of Pisa list), as important skill in the process of object designing

A particular advice from a teacher warns us *"It is important for pupils to see the relevance of the mathematics but pupils must not be "turned off" from over use of maths"*

According to the Panel, examples of **physical objects** which could be printed in **pupil-led trials**, based on top critical mathematical literacy items, are:

- Classic 3D Fractals
such as Sierpinsky Tetrahedron or the Menger Sponge

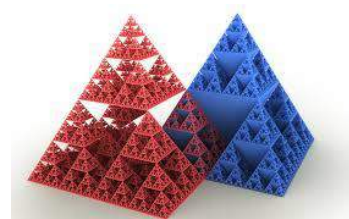

Sierpinsky Tetrahedron

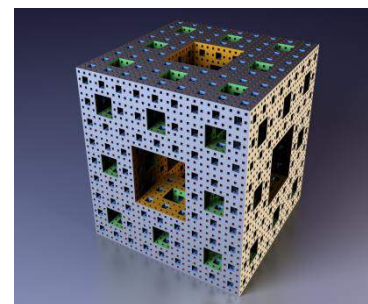

Menger Sponge

- A cube, a square pyramid or a cylinder
- An object in balance over a suitable support, so that the lower shaft is perfectly horizontal

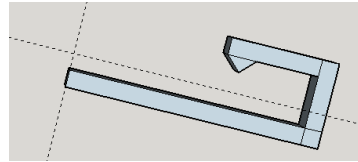

- A shoe
- An electronically customized last.
(A last is a mechanical form in the shape of human foot. It is made of wood, iron or plastic and used invariably in shoe production. The problem with lasts is that they all come in pre-given sizes.)



- A toy airplane

In order to design pupil-led trials, we note that some objects are directly connected with maths topics which were identified for priority and feasibility (mainly “Relationships within and among geometrical objects in two and three dimensions”). Other objects (shoes, lasts, toy airplane) are just indirectly connected with maths topics. Perhaps they may better enhance the pupils’ practical attitude, but teachers have to define them analytically in order to connect them to maths topics.

Regarding the relevant **didactic and practical methodology** to adopt during maths-oriented 3D printing **pupil-led experimentations**, below you will find quotations from some experts, who pointed out these main possibilities:

A. "The teaching course could be divided into 3 modules. At the end of each module students will have to comply with certain tasks and assignments which will be collected in the final project's book. In Module 1, frontal lectures will teach students basic information about the object to print and about the tools and technical equipment (software and machinery) available for their experimentation. In Module 2, pupils will study the features and design each part of the object. They will also receive instructions to evaluate and assess correctly all the values, to complete a survey with the traditional tools or thanks to pictures or laser scans. In Module 3, students will print the object in the lab, after receiving specific instructions on how to operate the machine".

B. "The practical organization should begin with the students being given gear drawings and mathematical laws that gears motion is subject to. They should then proceed to a creation of a simple mechanism that has a certain axial rotational speed. Difficulty could be adjusted by using not just spur gears and include helical or worm ones."

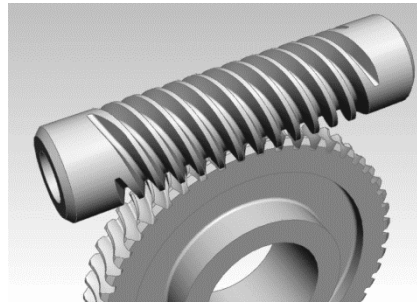

C. "The whole group should participate in the choice of the object to be printed. This group should be divided into sub-groups that address the various phases of design and construction of the product:

1. Processing of mathematical functions necessary for the realization of the object.
2. Processing of the 3d model through Autocad software.
3. Physical realization of the object through the 3d printer, which should assist the entire group involved."

D. "A good practical organization could be letting students design the surface directly with a Maths program such as *Derive*. When they have designed these surfaces, the design can be treated with CAD programs (*Magics, 3D Studio, Rhinoceros...*) to give thickness, or it can be manipulated and finally sent to *Cura, Repetier Host*, to construct it with a 3D printer."

E. "Pupils could be organized into groups or cells and work on different aspects of the print, called collaborative learning. Another way to organize this would be to have pupils working on different aspects of a project, so that some pupils are working on different projects which may be easier or quicker to use. This would mean that the printer could be used continuously throughout a project. "

F. One of the experts highlights an extremely interesting and valuable document on 3D printing issued by the Harvard University in the US. Contents are highly technical and suitable for specialists, but some insights could be useful at this level as well. The documents can be freely downloaded from <http://www.math.harvard.edu/~knill/3dprinter/documents/trieste.pdf>

II.1-1.A.2 SCIENTIFIC LITERACY

Concerning scientific literacy, according to the results of First Round Questionnaire top critical item is:

INTERPRET DATA AND EVIDENCE SCIENTIFICALLY with 3,89 average

The Panel generally agrees with this evaluation, also in Second Round Questionnaire. A few more proposals point out further capabilities as crucial skills to develop effective **pupil-led trials**:

- **Explain phenomena scientifically**, by "focusing on the identification, usage, generation of explanatory models and representation. Through that way, a student can easily visualize and experiment on theoretical models or just models that he is used in seeing just on paper."

- **Problem Solving:** while designing an object," it is important to identify the difficulties and find strategies to solve the problems".

According to the Panel, examples of **physical objects** which could be printed in **pupil-led trials**, based on top critical scientific literacy items, are:

- Structure of most common chemical molecules
- An object from students' daily life, such as a smartphone cover or a key ring
- An electronically produced shoe pattern.
(A shoe pattern is the upper part of a shoe as cover on the sole. In the production of shoes, there is the necessity to check whether the pattern matches the sole by dressing up the last with the pattern. This is often done with folded paper by hand)
- A house with yard, or the school plastic model
- A vase
- Objects in which to study the centers of gravity

- Triple gear involves using three toothed-rings, all pairwise linked.
- Triple Helix is a mechanism with three helical gears, meshing in pairs, all at right angles to each other.



Helical gear

- Students could develop their own "linear to circular movement transformation" based on Leonardo Da Vinci's ideas, and also make their own experiment about volume transformation.



Toothed gear wheels

- A stirling engine

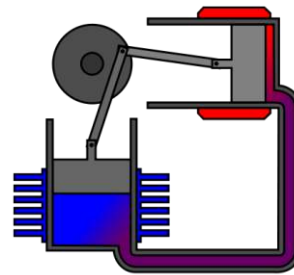

- Design and manufacture of a **scale size space rocket**, which could actually be tested. This would use rocket motors similar to fireworks. The two main areas to test and experiment around would be the nose cone and the tail fin where the rocket motor is fitted.

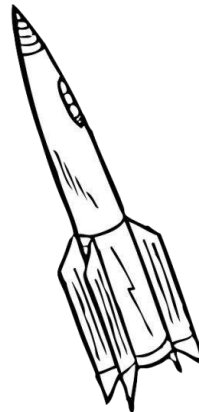

In order to design pupil-led trials, we note that some objects are directly connected with science topics (mainly “Structure” and “Properties of matter”, “Motions and forces, action at a distance”) which were identified for priority and feasibility. Other objects (house, vase, engine, space rocket) are only indirectly connected with science topics. Perhaps they may better enhance the pupils’ practical attitude, but teachers have to define them analytically for their connection to science topics.

Regarding the relevant **didactic and practical methodology** to adopt during science-oriented 3D printing **pupil-led experimentations**, below you will find quotations from some experts, who highlighted these main possibilities:

A. "The teacher could show the pupils a complex structure where a particular is missing. The missing piece could be the object they have to print: pupils should then guess which is the real shape of the object and its size. To make things more difficult, the teacher could show the incomplete structure as a 2D sketch or maybe a 3D cad work. He could also ask pupils to resize the object to a smaller or a bigger scale. One more task pupils would have to undergo is, after having devised what is the shape to be printed, which orientation is best for a successful printing. Here physics laws should help them. To make an example, if they have to print the base of a square pyramid it wouldn't be wise to put on the floor the smaller square because the hot material from the printer's nozzle could solidify in an unwanted way."

B. Identifying Operational Steps such as:

- 1 – Identification of the object to print
- 2 – Drawing of the object

3 – Finding instructions about how to print the object

4 – Printing of the object

5 –Use of the object

C. About designing and printing shoes and shoe patterns:

- "A certain set of various used shoes is handed in to the pupils. Pupils are asked to reproduce the shoes through mathematical measurements, technical calculations and 3d printing."
- "Lasts in various sizes are handed in to the pupils. They are asked to make the necessary measurements and transfer their collected data to the computer. They are expected to come out with electronically produced shoe patterns that eventually fit their model lasts well. "

- **D.** About designing a house:

"Students with the guidance of the teacher will plan to scale each component of the house. The windows, the roof, doors, furniture for each room, courtyard. The project will be assigned to groups of students that need to cooperate to complete the house"

- **E.** About designing and printing stirling-engine components:

"Students study stirling engine operation, and once they understand its operation they will design their own object and then manufacture it with a 3D printer, so they can view it in operation, and of course a better understanding on real-time as it behaves"

- **F.** To design and print a space rocket, teachers should first give the following inputs:

1. Physics: gravity, aerodynamics, trajectory, forces, speed, height and measurements

2. Chemistry: energy, oxidation, fuels, reactions, rates of reactions and physical experimentation.

3. Maths: maths would be used in all processes above

II.2.- 2.A KNOWLEDGE/CONTENT TOPICS

II.2.- 2.A.1 MATHS: ITEMS RELATING TO PRIORITY/FEASIBILITY FOR 3D PRINTING

Concerning mathematical topics and their priority/feasibility for **teacher-led 3D printing trials**, according to the results of First Round Questionnaire top items are:

- RELATIONSHIPS WITHIN & AMONG GEOMETRICAL OBJECTS IN 2 AND 3 DIMENSIONS
4,17 average priority 4,44 average feasibility
- MEASUREMENT 4,11 average priority 4,50 average feasibility

The Panel as a whole confirmed the general assumption, that *2D & 3D relationships within objects* is the most important content topic on which **teacher-led 3D printing trials** should be based. Only three experts prefer *Measurement* to design the experimentations.

Regarding examples of printable objects, the general concern is that it could be difficult to find something which has to deal with maths knowledge primarily.

An expert notices "it could be very difficult to create a 3D printing project which is primarily designed from a maths perspective. It would be far easier to choose a project with a scientific theme and then look at how maths could be used within the project. One starting point might be the design and printing of a simple **house**. If the house was to be built to a scale size, eg 1:100 simple measuring and basic maths could be used."

Further examples of **printable objects** in maths-oriented **teacher-led trials** are:

- Design inspired by Apollonius' circles

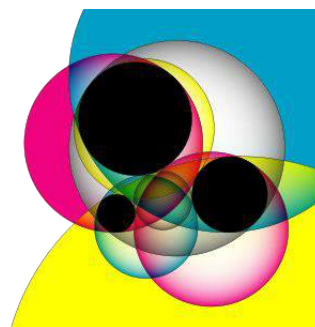

- Design inspired by Voronoi Tessellation

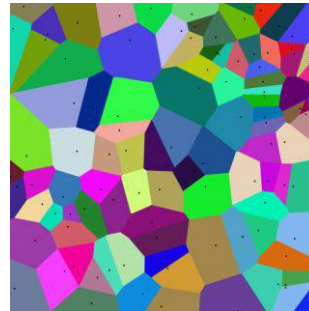

- Lunes of Hippocrates

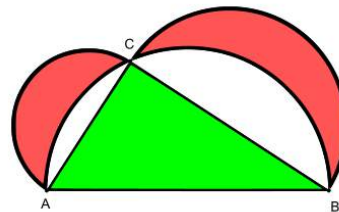

- 3D Solids (cubes, cylinders, spheres, cones, pyramids) with internal cavities

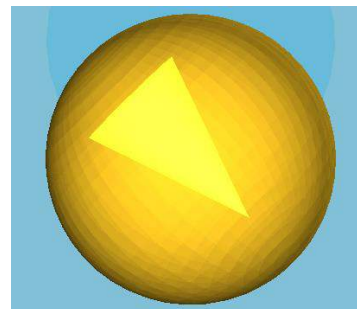

- A shoe pattern cutting plotter machine, or just a component.
(A plotter machine is a much-used technological instrument in the exact cutting of shoe patterns in shoe manufacturing. Chinese producers have strong presence in the global market for plotter machines.)

- A Möbius strip

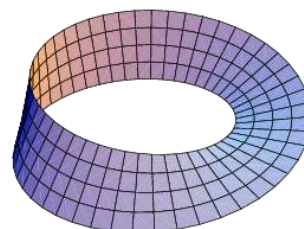

Regarding the relevant **didactic and practical methodology** to adopt during maths-oriented 3D printing **teacher-led experimentations**, below you will find quotations from some experts, who propose these ways to go:

A. "It is necessary to create several separate groups but at the same time connected. Each group should follow specific phases of the project, obviously all the problems and their solutions should be approved by the whole group."

B. "The teacher could, at first, just ask pupils to identify a solid of their choice giving a specific volume they have to follow. The pupils could then decide (in small groups) which is the best solid to work on and which dimensions (length, height, width) they should choose to fit the task given to them by the teacher. The works would be examined and validated at the end, so that printing could begin."

C. Identifying Operational Steps such as:

1. Presentation of the problem from the mathematical and the historical points of view
2. Building of the object
3. Use of the kit for repeated trials
4. Generalization from the mathematical point of view

D. About 3D solids with internal cavities: "Students could observe and study the sphere and its positions and equilibrium depending on the positioning of the centre of gravity within the cavity. The students can then make measurements of average density by studying the flotation. Even by simply describing the object with accuracy and with all the necessary details, the students will be engaged in the activity and therefore the learning process in terms of geometrical vocabulary will certainly be beneficial. The flotation of similar objects can therefore give new spurs for further activities and projects that are still to be designed and tried."

II.2. - 2.A.2 SCIENCE: ITEMS RELATING TO PRIORITY/FEASIBILITY FOR 3D PRINTING

Concerning scientific topics and their priority/feasibility for 3D printing trials, according to the results of First Round Questionnaire top items are:

PHYSICAL SYSTEMS – **Structure of Matter**: **3,89** average priority; **3,78** average feasibility

PHYSICAL SYSTEMS – **Motion and Forces** and action at distance; **3,50** average priority **3,56** average feasibility

Experts in this section shows different opinions about the most relevant topic in **science-oriented teacher- led trials**. While about half of them rate "Structure of Matter" as **the** top item, other experts choose "Motion and forces".

A few of them point out further content/knowledge topics that in their opinion should be carefully considered while designing a **teacher-led trial**:

- "Active studying and research, creative and independent reasoning, perseverance, seeking alternative solutions".
- "Cosmologic models; organic molecules; study of human and animal organs."
- "The most relevant topic for 3D printing is **Properties of Matter** because it shows the difference in usefulness between two objects with the same shape and size but made by different materials".

Examples of **printable objects** in science-oriented **teacher-led trials** are:

- Inorganic or organic molecules (i.e. glucose)

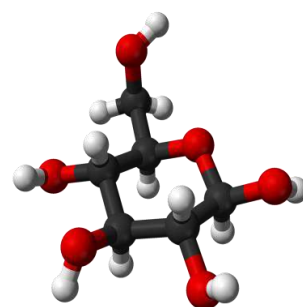

- An **atom** and its particles (ions, protons, electrons)

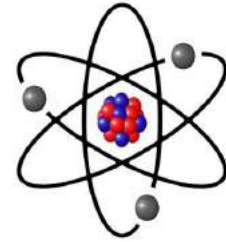

- The chemical structure of **Methane**

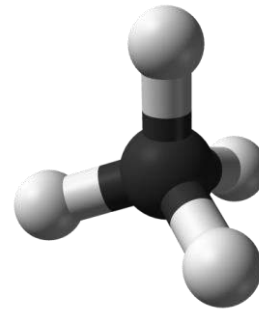

- Archimedes' screw

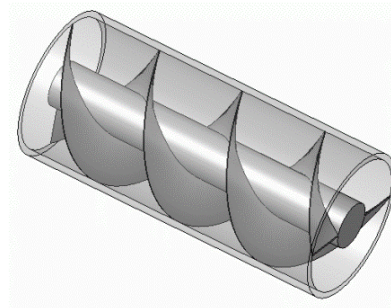

- **Toy cars** with plenty of details and accessories (such as wheel, electric motor, gears)
- Rail transport, such as **Maglev train** (magnetic levitation)
- Water transport, such as **high speed boats**

Regarding the relevant **didactic and practical methodology** to adopt during science-oriented 3D printing **teacher-led experimentations**, below you will find quotations from some experts, who highlighted these main possibilities:

A. Using Reverse Engineering method to observe, design and print an object

B. "The teacher introduces the problem, shows the solid to be printed and talks about its final use (what physical forces it has to withstand, whether it is allowed to grow/shrink and whether it needs to be a conductor or not). He lets pupils decide which is the best material to be used (of course among those that a 3D printer can actually use) and urges them to print their decision. He could then show how different materials chosen by pupils withstand more or less the physical forces by inserting the printed object inside the engine where it was meant to work. A gear made of a fragile material could break up in a few seconds. A gear made of the wrong material could change size (if a change of temperature is produced) and work no more (it could even melt)."

C. About Archimedes' screw, **this** methodology should be used:

"1. Revise the information about the objects that the students already have (Archimedes' Principle or density)

2. Identify the characteristics to examine (volume, mass)

3. Identify the purpose of the experiment with the students and invite them to make suggestions to solve the problem (compare forces in water on objects of different shape and mass)

4. Printing of the object

5. Execution of trials in laboratory"

D. About toy cars:

" **S**tudents will be **s**plit into different groups to design their own toy car, and at the end of the experiment a race could be organized to see which is the fastest, once constructed, taking into account the principles of physics."

E. About trains and boats:

"These projects could be based around aerodynamics and how forces can act upon them. At a lower level, projects could be based around the manufacture of 3D printed object. The maths element of the project could be a simple "bolt on" part to the project. For example with the boat project a simple calculation about water displacement could be done. This could then link into mass, volume and weight."

II.3 Results Of *SECTION B: HOW TO USE (SOCIO-TECHNICAL VARIABLES)*

In the Second Round Questionnaire we asked experts to rate the Keywords and Trends emerging from Section B of the First Round Questionnaire.

Given the same Questions 1-10 (see above pages 14 to 20), the Panel was asked to rate each Keyword (for Question 1 and 2) from 1 (not important) to 5 (top important), and each Trend (Questions 3-10) from 1 (totally disagree) to 5 (totally agree), adding personal considerations for better understanding.

Experts have generally confirmed the views already expressed in the previous questionnaire. Each one gave the same ratings as before to the same questions, often strengthening their view with further explanations.

Keyword and Trends are definitely confirmed in the Second Round.

Question 1 - What kind of experts do you think is important to involve?

Ratings highlight **STEM teachers** as the priority experts to involve (**4,41** on average), followed by 3D printing technology experts (**4,31** on average) and CAD designers (**4,06** on average).

An expert suggests to involve also teachers of Arts and Art Historians as well.

Question 2 - What knowledge and skills must the experts have?

The most rated choice is "Awareness of 3D printers' opportunities and limitations for teaching purposes" (**4,24** on average), followed by CAD & Industrial Design skills (**4,12** on average) and a good pedagogical approach (**4,06** on average).

Question 3 - DEDICATED TRAINING: Do you think useful/necessary making teachers more informed about use of the printers with specific technical training?

Although the different trends still co-exist within the Panel, the majority of the experts find themselves somewhere **between Trend B. (*Basic Training Only*)** and **Trend C. (*Specific and intensive training*)**.

Most teachers tend to state that if they are not offered proper training, they won't be able to deliver good lessons and organize effective trials for the students.

On the opposite, business experts tend to encourage a Do-it-yourself approach in learning to operate a machine, with a need for just basic training.

About the educational issues attached to the project an expert says:

"Printing something in 3D is easy. Applying that to education is something else. I believe it is essential to properly train the teachers in features and limitations, otherwise 3D printers will be just fancy gadgets sitting in the corner of classroom."

Question 4 - TEACHING APPROACH: Do you think useful/necessary making teachers more informed about new approaches to teaching?

Trend C. is the most rated ("A variety of new teaching strategies in needed", **3,94** on average).

The Panel generally agrees with the need of a variety of learning strategies to engage the students in PRINT STEM project, and with the urge of introducing new technologies in didactics, as long as this does not erase traditional teaching, or forces teachers to radically change their own method.

Question 5 - How Can You Program The Involvement Of Business Experts/Technical Partners? (eg. Cad Experts, Computer Programmers, Technologists of printing process, Others – specify)

Trend B. is the most rated ("Feasible through partnerships with external institutions", **3,76** on average), even if most experts are concerned about the difficulty of find external partners for schools.

The most relevant views are expressed in the quotations as it follows:

"As a member of a Technical University that implements the 3D printing technology to its activities, I see a partnership between schools and Technical Universities feasible in the form of seminars or regular elective courses."

"Professional experts are the only effective source of programming and modeling at the moment because of the obvious facts 1)that teachers and pupils are new-comers to the field of 3d printing; 2) that it is an illusion to expect a sudden leap in their computer literacy skills. Hence schools have to find a way to pay for and ensure the involvement of professional experts in their curriculum."

Question 6 - Do you think it's important (and how much) a COOPERATIVE WORKING between experts from different categories? How can it be realized?

Trend B. ("Important and feasible", **3,82** on average) is higher than Trend a. ("Important but difficult", **2,94** on average).

The most argued views are quoted below:

"Many interdisciplinary studies are known and in the academia. First, around a particular topic the interest of experts in different fields converges. Then they work on a protocol of collaboration about

who is responsible for what and they set clear and definite time frames for each work to be done. Finally they collaborate. Usually, the synergy as the result of collaboration goes beyond anything each and every expert can individually produce. "

"Market connection is important, but not necessarily in learning time. It's interesting that companies can provide schools with new ideas related to it. More and more thinking around the fact that students in a few years can be incorporated in the world of work."

Question 7 - Do you think it's important (and how much) the presence of people permanently dedicated to technology for on-going support?

Trend A. is very highly rated ("Yes, permanently" **4,00** on average).

Most teachers are afraid that technical problems will stop the didactic benefit of a 3D printer in school, preventing useful and smooth exploitation of this technology.

Question 8 - Do you think it's important (and how much) the logistics of using the printer (like the accessibility of the machine as a motivational factor)?

Trend B. is very highly rated ("Very important" **4,00** on average),

Almost everyone confirms that students should have free access to the machine, although many teachers suggest some technical staff should supervise the printer to avoid damage or improper use.

The most relevant view is quoted in the following sentence:

"3DPrinting philosophy is to open the technology to users. When low cost 3dPrinting appear, also appear FABLAB concept. Fab Lab (fabrication laboratory) is a small-scale workshop offering digital fabrication. This concept must be transferred to schools. This "Lab" can be shared by teachers and students, of course, under a control."

Question 9 - Do you prefer to create from scratch the contents of experimentation ("MAKE" LOGIC)?

Question 10 - Do you prefer to purchase existing contents, eg. free program or freely downloadable designs from websites ("BUY" LOGIC)?

Here we report the aggregated results for the two questions together, as who prefers "make" logic wouldn't go for "buy" logic and vice versa. Each expert just confirmed the view already expressed in First Round Questionnaire, rating the same trend the same way he/she already did.

The most rated Trend, considering Questions 9 and 10 together, is **9B** ("Let's go for a mixed solution", **3,82** on average).

Whatever the opinion, an expert explains very well what should drive STEM teachers involved in the project in choosing the most suitable logic:

"Learning is a thorny issue and a bumpy road. It involves, by necessity, a gradual process with wrong turns, dead ends or complete breakdowns. The important point about is to gain and maintain the *momentum of cognitive motion*. Therefore, totally free of fear of failure and fully acknowledging that your past failures and mistakes are indeed your present feedback for your future success, the new users of 3d printing should start from scratch and keep building on the previous day's firm achievements."

CONCLUSIONS

This study aims at suggesting a possible working methodology to Schools involved in PRINT STEM project, most of all to those who are buying a 3D printer just now or are using the machine for the first time for didactic purposes.

The documents could be useful for dissemination purposes in the future as well, in case other European Schools want to adopt 3D printing technology to enhance STEM teaching.

PRINT STEM project identifies STEM teachers as key figures in the entire process. As the aim of the Project is strengthening STEM skills of students, teachers are necessarily involved in designing and delivering effective experimentations for pupils' engagement and development.

For this reason teachers have a great responsibility for the success of the project, so they should be confident in using the machine and managing a students' experimentation.

Considering our Panel's findings, teachers point out some issues to go through, such as:

- some perception of 3D printers as an "authorized-personnel-only" job
- some concerns about how the machine works and how to become acquainted with it
- some concerns about how to receive a proper training
- some concerns about which didactic approach would suit best

On the other side, there's also a very positive attitude from most teachers. We notice great expectations in particular from Schools who haven't delivered any 3D Printing trial to their students yet.

Considering our Panel's findings, we remark the following highlights:

- enthusiasm about new teaching and learning opportunities that come along with 3D printers
- desire of involving students in engaging and useful activities
- optimistic view about improvements in STEM subjects after making experiments with 3 printers
- confidence in being supported by a team of specialists who can be of help when needed

Furthermore, we underline the positive repercussion of being part of an international team, where every school and teacher can ask for support and rely on a learning and teaching community able to set questions and find answers.

We really thank each component of the Panel of Experts for his/her valuable contribution.

APPENDIX I. CRITERIA FOR THE PURCHASE OF TECHNOLOGY

I.1- FREE CONSIDERATIONS CONCERNING 3D PRINTERS TECHNOLOGY - HARDWARE

Expert 1	It's necessary to have a laboratory equipped with different 3D printing technology options. On the market you may find machines operating in very different ways from each other, although they reach similar results.
Expert 2	Cheap machines; fast in executing tasks; easy to use
Expert 3	Hardware is different from one another. Your choice depends on the use you have to do and on how much time you have. For example Maker Boot is cheaper but less effective than a laser 3D printer, which is more precise in designing details, and more versatile in nylon use and elasticity. Or you may go for chalk 3D printers although the material they use is not so strong. Costs are very different.
Expert 4	<ol style="list-style-type: none"> 1. Make a stock of spare parts that are susceptible to damage after some cycles of experiments 2. Register the more easily damaged parts (an expert can advise) 3. Get printers with heated beds 4. In the case of shortage of funds get DIY printers (e.g ULTIMAKER). Otherwise make your life easier getting the assembled ones. 5. If the goal of a specific project is the better understanding of 3d-printer structures get DIY printers.
Expert 5	I believe the 3d printer may have a fundamental role in the school. It is important for a student to study science subjects not only from a theoretical perspective: a student who sees an object studied theoretically take shape is definitely more stimulated and motivated. 3d printers hardware is rather simple, this leads to a possible realization of these printers in schools equipped with mechanical and electrical laboratories.
Expert 6	At this particular moment, as I said, 3D printing is in its infancy. While this is extremely interesting and stimulating, it has the disadvantage of offering fewer printer models with high prices and not a great printing quality. As it happened 20 years ago with inkjet and laser printers, we can expect prices to drop dramatically in the next few years, together with a remarkable improvement in the quality offered. We can expect future printers to be more and more accurate, allowing the production of more precise and more resistant objects. For this reason, a high expense in hardware now will mean the highly priced printers are obsolete in the future. This is something that occurs every day in the computer world but here more than ever. I would suggest to use a reasonable (but not enormous) budget when buying printers now, using money in teachers formation and in more theoretical subjects. Now it is the time to create 3D printing experts that will be using (for now!) not-so perfect machines. When technology will give us more sophisticated printers, we will be able to use them at full power.
Expert 7	///
Expert 8	///
Expert 9	<p>Regarding the hardware of 3D printers as a school our primary concern is the safety of these printers. 3D printing has many benefits, but potential risks must be evaluated, and we should consider safety concerns as part of their risk management approach. Their high-voltage power supplies, multiple moving parts and hot surfaces make 3D printers relatively complex. Therefore, when choosing the hardware our priority will be to minimize these risks.</p> <p>The second priority regarding the hardware would be low maintenance/repairs/faults/jams etc. Ideally the printer should be able to continuously print with low maintenance. The extruder head shouldn't jam and the wires shouldn't wear out etc.</p> <p>Such features like print size, print resolution, print speed and the material used should also be taken into consideration.</p> <p>Qualifications such as wireless LAN, Ethernet port and USB port will provide a convenient way to get the 3D model onto the device regardless of where you work and enabling to perform prints without a computer connection.</p>
Expert 10	<p>The mechanisms mentioned below should be taken in to consideration to supply the technology needed.</p> <ul style="list-style-type: none"> - Area and purpose of usage - The technology used

	<ul style="list-style-type: none"> - Size of the machine - Layer thickness - The interface between the printer and the files to be printed such as USB drive, wireless Lan, SD - Card Reader - User friendly - Speed and size of printing - Security - Accessibility and cost of consumables - After sale support
Expert 11	<ul style="list-style-type: none"> • the brand of printer chosen to have a local support network with qualified technicians in our region • the cost of consumables and spare parts are cheap • To stock the most commonly used parts • The brand of printer to have good reviews on the reliability of its products
Expert 12	///
Expert 13	Before buying a 3D printer it is important to gather information from companies who have been using that particular kind of printer. It is also important to buy a printer from a firm which has been on the market for some years, not from a new company.
Expert 14	Two major considerations to be taken in to account when choosing hardware: Reliability and ease of maintenance is essential in the classroom. Output speed is very important particularly when dealing with typical class sizes. Size of printer is not important in my opinion. Two small machines have a bigger output than one large one.
Expert 15	Reliability, ease of use, ease of maintenance and speed of print are all factors which need to be considered.
Expert 16	First considerations is surely the money. Low cost printers are often questionable in quality and reliability. Due to slow printing time, one printer is not enough for a school. Cost of supplies and maintenance should be taken into account.
Expert 17	///
Expert 18	///
Expert 19	<p>We think the best is to purchase the printers in the country of origin, to ensure proper maintenance and of course a good support.</p> <p>The cheapest actually are FDM desktop printers, and within such printers specifically the Prusa I3, which leaves do it yourself is the best price offers on market???, plus it is easy to look inside the printer, so that students can understand simply the machine functionally, which is very simple. There are also other printers of this type, but most commercial such as "Makerboot" among others. The material is very economical, about 20 € / kg (ABS), and can be purchased at any website, in a multitude of colors, including flexible material, and other different materials with different properties. It is important that the provider gives you as stable a material as possible to avoid problems in the extrusion thereof. In addition there are plenty of forums where you can get lot of information. There are also pages with libraries of parts, so that in the case of not knowing design, to also manufacture your own pieces.</p>

I.2 - FREE CONSIDERATIONS CONCERNING 3D PRINTERS TECHNOLOGY - SOFTWARE

Expert 1	In the "sharing" era, we should definitely give up property softwares and use open source softwares as much as we can.
Expert 2	///
Expert 3	Let's go for open source software like SketchUp for example.
Expert 4	<ol style="list-style-type: none"> 1. Start with the suppliers software. 2. If the goal of the project is the expansion of programming skills take advantage of the open source software. 3. Take advantage of free designs and experiments and then move on to the "make" logic.
Expert 5	I think the 3d printing software are simple and intuitive . Then students will realize how it is easy to create a 3d model after an initial phase of knowledge of the potential of such programs, also a key fact is that the software is readily available in the network.
Expert 6	Nearly the same considerations that I made about the hardware could be used for the software part: even installing a 3D printer is more complicated now than it will be in the future, we are far from the "plug and play" experience that we see when installing other type of peripherals. An accurate research of the best combination driver-software should be studied, using in particular the experience found in the forums community. Freeware rendering and modeling software is for now the best choice thanks to the many contribution (and frequent updates) it can benefit from the programmers community. The only paid software that could be used readily is, in my opinion, the AUTODESK suite, for its already wide base of worldwide users. (and its presence in many schools)
Expert 7	///
Expert 8	We should definitely go for open source software
Expert 9	As we do not have commercial concerns it is not really necessary to use professional softwares. We should avoid hard, complex and boring softwares that can bore the pupils and undermine their active learning process. Instead free 3D design softwares especially ones for educational purposes will be more beneficial. When choosing the software we should consider features like ease of use, attainability, simplicity and being browser-based. Having an entertaining interface will stimulate the pupils interest and promote their creativity.
Expert 10	First of all it is important that the software and hardware is compatible and support each other. This will help to minimize the product cost and also it will affect the product quality. Simple web based softwares and free downloadable designs from websites can be a useful tool to start with when we consider the inexperience of teachers and pupils. However after trainings and on-going support pupils and teachers can be introduced with more professional softwares.
Expert 11	<p>The software has the following characteristics</p> <ul style="list-style-type: none"> • Be open source software so that evolves and continuously improved • Be creative commons license • Be easy to use even by people without specialized ones knowledge in ICT
Expert 12	///
Expert 13	The software must be open source, at least the software which makes the printer work. In the past few years our school has bought some programs for 3D drawing.
Expert 14	The software needs to be intuitive and easy to access on a basic level, but also allow for skills growth and the ability to generate complex designs. On line support, web based communities and access to open source material are vitally important to support effective teaching and learning. Clearly this material must have a simple interface with the CAD software.
Expert 15	Ideally it would be to an industry standard or used in industry as pupils will be learning software skills which would be valuable and recognized. However in education cost needs to be kept to a minimum. Open source software is wide spread and could be used by schools. Choosing software that is easy to use, popular and straight forward when interfacing with 3D Printing hardware are all considerations which need to be taken into account.
Expert 16	Current software is difficult to use, requires good hardware and generally lacks models and schemes suitable for education needs. Language availability is also serious issue. I don't see teachers using advanced software in the language which they don't fully understand. Teachers should first be trained how to use software efficiently and this training will not be easy for all of them. Printing teacher-dictated chemical molecules (for example) will not serve any educational purpose.
Expert 17	///

Expert 18	///
Expert 19	For the printers function we need Marlin form software configurations about Arduino. Cura/RepetierHost for machine configuration, material specifications, and CAD slicing, etc. Sketchup, Rhinoceros, 3D Studio, Solid Works, Solid Edge, Catia, etc, to obtain the 3D design, needed to obtain the models, and then export it to a .stl file.

APPENDIX II - HARDWARE SPECIFIC INFORMATION

There's a lot of technologies on the market but not so much low cost technology using low cost materials. In Europe there are more than 200 providers for the same reprop technology. But all these providers facilitate just 2 different models:

PRUSA I3



DELTA



Another issue is related to filament thickness, in market just 2: 1.75 mm and 3 mm. You need to buy filament related to your nozzle size.

Related to material, on the market you can find ABS and PLA with a lot of colour combinations

APPENDIX III - SOFTWARE SPECIFIC INFORMATION

1) SOFTWARE TO CONTROL 3DPRINTER

SLIC3D and CURA are more popular platforms. But ALL 3D PRINTERS (REPRAP MODELS) can be controlled BY SAME SOFTWARE

This is a list of software:

Software	Developer	Print Preparation	Slicing	Comment
Cross Platform Tools				
Ultimaker Cura	Ultimaker	Yes	Yes	Cura is the open-source printer control software developed by Ultimaker. However, the software can be used with other 3D printers. Intuitive, fast and easy to use, Cura is our pick for 3D printing beginners looking for a robust yet simple to use 3D printer front end.
KISSlicer	KISSlicer	Limited	Yes	KISSlicer is a cross-platform G-code generator for 3D printers. Generates excellent slicing results albeit a somewhat dated user interface. Exists both in free and premium versions.
Repetier Host	Hot-World GmbH & Co. KG	Yes	Yes	Repetier Host is an open-source 3D printer front-end. It uses Slic3r as default slicing engine but Skeinforge is also available.
ReplicatorG	ReplicatorG	Yes	Yes	ReplicatorG is an open-source 3D printer front-end using Skeinforge as slicer. The software will drive MakerBot, Thing-O-Matic, CupCake CNC, RepRap printers or generic CNC machines.
Slic3r	Slic3r	Yes	Yes	Slic3r is a popular cross-platform slicer. This open source slicer is fast, generates good results but its settings needs some tweaking initially.
Skeinforge	Skeinforge	No	Yes	Skeinforge was once the slicing standard. However, the software is slow for today's standards and has begun to fall out of fashion.
Platform Dependent Tools				
MakerWare	Makerbot	Yes	Yes	MakerWare is the front-end printing software from MakerBot. Easy and intuitive to use but MakerWare is designed only for the MakerBot 3D printers. The software uses MakerBot Slicer as the default slicer.
UP	Beijing TierTime	Yes	Yes	The software for all UP! 3D printers.

Software	Developer	Print Preparation	Slicing	Comment
	Technology Co. Ltd.			

2) SOFTWARE FOR 3D MODELLING

In this way, on the market exists a lot of free and non-free software to design 3d models. Sketchup or Thinkercad are easier to use.

This may be a useful list :

Software	Developer	User Level	Price	Comment
CAD Tools				
123D Design	Autodesk Inc.	Beginner	Freemium	123D Design is a powerful, yet simple 3D creation and editing tool. The free version gives you access to most features and allows you to create and use 3D models for non-commercial purposes.
3DTin	Lagoa	Beginner	Free	3DTin is a free, browser-based 3D modeling tool that is both easy and intuitive to use, especially aimed at beginners. Once you have created a user account you also get access to the huge repository of Creative Commons 3D models.
CubeTeam	Otherlab Inc.	Beginner	Free	CubeTeam is a multiplayer 3D painting and modeling program that lets you and your friends imagine worlds out of cubes and then print them in 3D. CubeTeam is free, runs in a web browser, and has powerful editing tools that let you create in a virtually limitless environment.
Cubify Invent	3D Systems Inc.	Beginner to Intermediate	€39 (\$49)	Cubify Invent is an easy-to-learn 3D modeling tool aimed at helping users to quickly create 3D printable files. The software which comes with free tutorials does only run on Windows though.
Design Spark Mechanical	RS Components/Allied Electronics	Beginner to Intermediate	Free	DesignSpark Mechanical is a 3D modeling software developed by the electronics distributor RS Components/Allied Electronics. The software equips all engineers with 3D design capability and it is said to be fast and easy-to-use.

Software	Developer	User Level	Price	Comment
FreeCAD	FreeCAD Community	Intermediate	Free	FreeCAD is a parametric 3D modeler built for product design and engineering. Feature rich and with a high learning curve, FreeCAD is rather for advanced users. The software is multi-platform, and runs flawlessly on Windows and Linux/Unix and Mac OSX.
Geomagic Design	3D Systems Inc.	Intermediate	€1799	Geomagic Design is a comprehensive and robust mechanical CAD design tools, allowing ideas to go from concept to production for professional engineers, makers, students and hobbyists. Geomagic Design is available in three versions: Personal, Professional and Expert, each tailored to the needs and budgets of the respective user base.
Inventor	Autodesk Inc.	Intermediate to professional	\$7295	Inventor 3D CAD software offers an easy-to-use set of tools for 3D mechanical design, documentation, and product simulation.
Rhino 3D	Robert McNeel & Associates	Intermediate to professional	€995	Rhinoceros (aka Rhino) is a stand-alone, commercial NURBS-based 3D modeling software commonly used for industrial design, architecture, marine design, jewelry design, CAD / CAM and rapid prototyping. Rhino's popularity is based on its diversity, low learning-curve, relatively low cost, and its ability to import and export over 30 file formats, which allows it to act as a 'converter' tool between programs in a design workflow.
SketchUp	Trimble Navigation Ltd.	Beginner to Intermediate	Free - €378	SketchUp is a 3D modeling program for applications such as architectural, interior design, civil and mechanical engineering. Its powerful yet easy to use interface make it ideal for beginners in 3D modeling. A freeware version, SketchUp Make, and a paid version with additional functionality, SketchUp Pro, are available. Note that the free version does not allow you to export to *.stl for 3D printing, you'll need to install a plug-in to do so.
Solidworks	Dassault Systèmes Solidworks Corp.	Intermediate to professional	\$3995	SolidWorks is a 3D mechanical CAD program widely used amongst engineers and designers. The software features powerful simulation, motion, and design validation tools, advanced wire and pipe routing functionality, reverse engineering capabilities, and more.
TinkerCAD	Autodesk Inc.	Beginner	Freemium	TinkerCAD is a browser based 3D modeling program ideal for beginners. You can save your designs online or share them with others. Export *.stl files to print with your own 3D

Software	Developer	User Level	Price	Comment
				printer or send your designs to one of popular 3D printing services.
Freeform Modeling Tools				
123D Creature	Autodesk Inc.	Beginner	Freemium	123D Creature is an iPad app that gives anyone the ability to create amazing 3D characters. Design your creature, then sculpt detailed features before adding skin, fur or feathers as surface texture. Export your finished creature as an image, 3D model or have it 3D printed into a real sculpture!
3ds Max	Autodesk Inc.	Professional	\$3675	3ds Max 3D modeling software provides a comprehensive modeling, animation, simulation, and rendering solution for games, film, and motion graphics artists.
Blender	Blender Foundation	Intermediate to professional	Free	Blender is a free and open source 3D animation suite. It supports the entirety of the 3D pipeline—modeling, rigging, animation, simulation, rendering, compositing and motion tracking, even video editing and game creation
Cinema 4D	Maxon Computer GmbH	Professional	\$3695	CINEMA 4D Studio is a 3D modeling, animation and rendering application for professional 3D artists wanting to create advanced 3D graphics. The software is capable of procedural and polygonal/subd modeling, animating, lighting, texturing, rendering.
Maya	Autodesk Inc.	Professional	\$3675	Maya, is 3D computer graphics software offering a comprehensive creative feature set for 3D computer animation, modeling, simulation, and rendering. It is used to create interactive 3D applications, including video games, animated film, TV series, or visual effects.
Sculpting Tools				
123D Sculpt	Autodesk Inc.	Beginner	Freemium	123D Sculpt is a tactile modeling app for iPad. Use your fingers to push, pull, pinch and grab the material just as if you were modeling using clay.
Cubify Sculpt	3D Systems Inc.	Intermediate	€99	Cubify Sculpt is an organic modeling tool that enables sculpting with virtual clay. The software has mash-up capability and exports 3D print ready *.stl files.

Software	Developer	User Level	Price	Comment
Leopoly	Leonar3Do International Inc.	Beginner	Freemium	Leopoly is a web-based, social 3D sculpting application. Each of the created and saved models are available for the entire Leopoly community for shaping them further. Note that you cannot export your 3D models unless you have a paying account.
Sculptris	Pixologic Inc.	Intermediate	Free	Sculptris is a virtual sculpting software program, with a primary focus on the concept of modeling clay. Currently available for MacOS and Windows.
SculptGL	Stephane Ginier	Intermediate	Free	SculptGL is a browser-based 3D sculpting application well suited for intermediate users. The application does allow you to export in *.stl format, an interesting feature for anyone who has their own 3D printer.
ZBrush	Pixologic Inc.	Professional	\$795	ZBrush is a digital sculpting tool that combines 3D/2.5D modeling, texturing and painting. It uses a proprietary "pixol" technology which stores lighting, color, material, and depth information for all objects on the screen.